

異径両口 リングジョイント

C3604BD

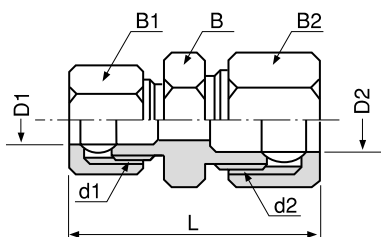
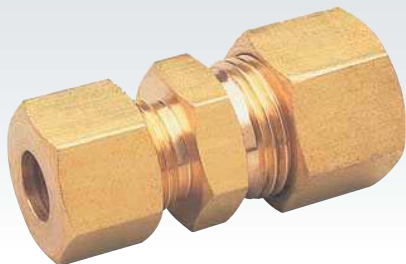

品番	適用管外径		寸法 (mm)					
	ϕ D1	ϕ D2	B	B1	B2	d1	d2	L(約)
RE-0602	6	6.35	14	17	17	PF1/4	PF1/4	40
RE-0608	6	8	14	17	17	PF1/4	PF1/4	41
RE-0603	6	9.53	17	17	21	PF1/4	PF3/8	43
RE-0610	6	10	17	17	21	PF1/4	PF3/8	43
RE-0208	6.35	8	14	17	17	PF1/4	PF1/4	41
RE-0203	6.35	9.53	17	17	21	PF1/4	PF3/8	43
RE-0210	6.35	10	17	17	21	PF1/4	PF3/8	43
RE-0803	8	9.53	17	17	21	PF1/4	PF3/8	44
RE-0810	8	10	17	17	21	PF1/4	PF3/8	44
RE-0310	9.53	10	17	21	21	PF3/8	PF3/8	45
RE-0312	9.53	12	22	21	24	PF3/8	PF1/2	51
RE-0304	9.53	12.7	22	21	24	PF3/8	PF1/2	52
RE-0315	9.53	15	24	21	27	PF3/8	PF5/8	51
RE-0305	9.53	15.88	24	21	27	PF3/8	PF5/8	52
RE-1012	10	12	22	21	24	PF3/8	PF1/2	51
RE-1004	10	12.7	22	21	24	PF3/8	PF1/2	52
RE-1015	10	15	24	21	27	PF3/8	PF5/8	52
RE-1005	10	15.88	24	21	27	PF3/8	PF5/8	53
RE-1204	12	12.7	22	24	24	PF1/2	PF1/2	56
RE-1215	12	15	24	24	27	PF1/2	PF5/8	56
RE-1205	12	15.88	24	24	27	PF1/2	PF5/8	57
RE-0415	12.7	15	24	24	27	PF1/2	PF5/8	57
RE-0405	12.7	15.88	24	24	27	PF1/2	PF5/8	58

両口ロックナット付 リングジョイント

C3604BD

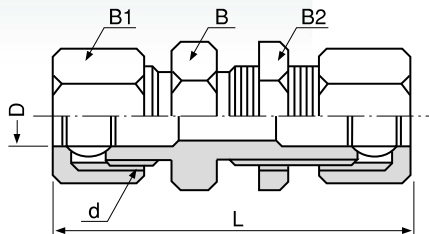
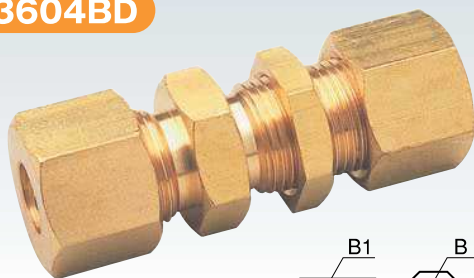

品番	適用管外径	寸法 (mm)				
	ϕ D	B	B1	B2	d	L(約)
RW-2206	6	17	17	17	PF1/4	52
RW-2202	6.35	17	17	17	PF1/4	52
RW-2208	8	17	17	17	PF1/4	53
RW-2303	9.53	19	21	19	PF3/8	59
RW-2310	10	19	21	19	PF3/8	60
RW-2412	12	23	24	23	PF1/2	73
RW-2404	12.7	23	24	23	PF1/2	74

ロックナット

C3604BD

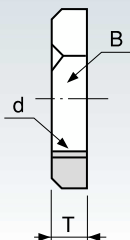

品番	寸法 (mm)		
	d	B	T
NR-1001	PF1/8	15	4
NR-1002	PF1/4	17	5
NR-1003	PF3/8	19	5
NR-1004	PF1/2	23	6
NR-1006	PF3/4	30	7

リングエルボ

C3604BD

C3771BD

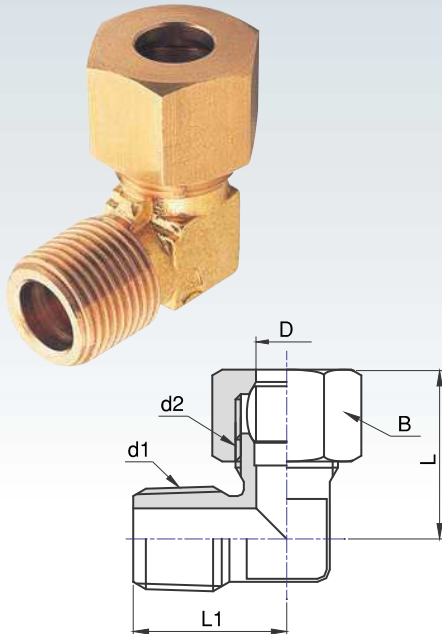

品番	取付ネジ	適用管外径 ϕD	寸法 (mm)			
	d1		B	d2	L1	L(約)
RL-1104	PT1/8	4	12	PF1/8	17	19
RL-1105	PT1/8	5	12	PF1/8	17	19
RL-1106	PT1/8	6	12	PF1/8	17	20
RL-1102	PT1/8	6.35	17	PF1/4	19	25
RL-1108	PT1/8	8	17	PF1/4	19	26
RL-1103	PT1/8	9.53	21	PF3/8	21	30
RL-1110	PT1/8	10	21	PF3/8	21	30
RL-1206	PT1/4	6	17	PF1/4	22	25
RL-1202	PT1/4	6.35	17	PF1/4	22	25
RL-1208	PT1/4	8	17	PF1/4	22	26
RL-1203	PT1/4	9.53	21	PF3/8	24	30
RL-1210	PT1/4	10	21	PF3/8	24	30
RL-1212	PT1/4	12	24	PF1/2	28	36
RL-1204	PT1/4	12.7	24	PF1/2	28	37
RL-1306	PT3/8	6	17	PF1/4	25	27
RL-1302	PT3/8	6.35	17	PF1/4	25	27
RL-1308	PT3/8	8	17	PF1/4	25	28
RL-1303	PT3/8	9.53	21	PF3/8	25	30
RL-1310	PT3/8	10	21	PF3/8	25	30
RL-1312	PT3/8	12	24	PF1/2	28	36
RL-1304	PT3/8	12.7	24	PF1/2	28	37
RL-1315	PT3/8	15	27	PF5/8	33	41
RL-1305	PT3/8	15.88	27	PF5/8	33	41
RL-1406	PT1/2	6	17	PF1/4	29	32
RL-1402	PT1/2	6.35	17	PF1/4	29	32
RL-1408	PT1/2	8	17	PF1/4	29	33
RL-1403	PT1/2	9.53	21	PF3/8	29	35
RL-1410	PT1/2	10	21	PF3/8	29	35
RL-1412	PT1/2	12	24	PF1/2	29	36
RL-1404	PT1/2	12.7	24	PF1/2	29	37
RL-1415	PT1/2	15	27	PF5/8	32	41
RL-1405	PT1/2	15.88	27	PF5/8	32	41
RL-1460	PT1/2	19.05	30	PF3/4	32	44
RL-1612	PT3/4	12	24	PF1/2	34	39
RL-1604	PT3/4	12.7	24	PF1/2	34	40
RL-1615	PT3/4	15	27	PF5/8	34	41
RL-1605	PT3/4	15.88	27	PF5/8	34	41
RL-1606	PT3/4	19.05	30	PF3/4	34	44

内ネジ・リングエルボ

C3604BD

C3771BD

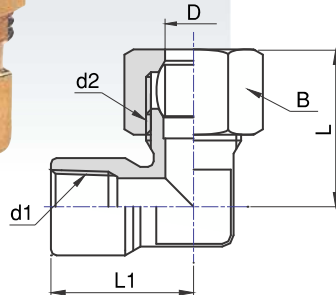
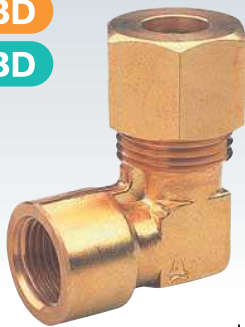

品番	取付ネジ	適用管外径 ϕD	寸法 (mm)			
	d1		B	d2	L1	L(約)
RL-5203	PT1/4	9.53	21	PF3/8	25	30
RL-5210	PT1/4	10	21	PF3/8	25	30
RL-5312	PT3/8	12	24	PF1/2	29	36
RL-5304	PT3/8	12.7	24	PF1/2	29	37

両口リングエルボ

C3604BD

C3771BD

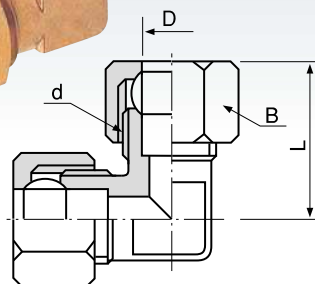
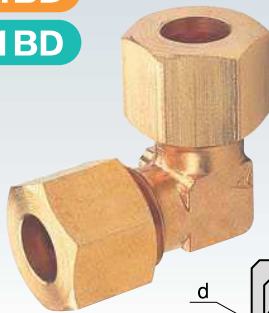

品番	適用管外径 ϕD	寸法 (mm)		
	B	d	L(約)	
RL-2104	4	12	PF1/8	19
RL-2105	5	12	PF1/8	19
RL-2106	6	12	PF1/8	20
RL-2206	6	17	PF1/4	25
RL-2202	6.35	17	PF1/4	25
RL-2208	8	17	PF1/4	26
RL-2303	9.53	21	PF3/8	30
RL-2310	10	21	PF3/8	30
RL-2412	12	24	PF1/2	36
RL-2404	12.7	24	PF1/2	37
RL-2515	15	27	PF5/8	41
RL-2505	15.88	27	PF5/8	41
RL-2606	19.05	30	PF3/4	44

三方リングチーズ

C3604BD

C3771BD

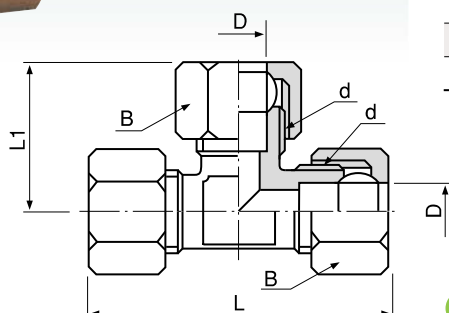

品番	適用管外径 ϕD	寸法 (mm)			
	B	d	L1(約)	L(約)	
RT-3104	4	12	PF1/8	19	38
RT-3105	5	12	PF1/8	19	38
RT-3106	6	12	PF1/8	20	40
RT-3206	6	17	PF1/4	25	50
RT-3202	6.35	17	PF1/4	25	50
RT-3208	8	17	PF1/4	26	52
RT-3303	9.53	21	PF3/8	30	60
RT-3310	10	21	PF3/8	30	60
RT-3412	12	24	PF1/2	36	72
RT-3404	12.7	24	PF1/2	37	74
RT-3515	15	27	PF5/8	41	82
RT-3505	15.88	27	PF5/8	41	82
RT-3606	19.05	30	PF3/4	44	88

サービス・リングチーズ

C3604BD

C3771BD

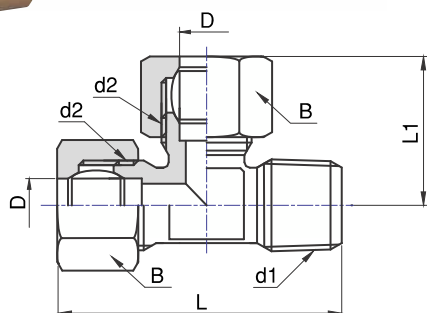

品番	取付ネジ	適用管外径 φD	寸法 (mm)			
	d1		B	d2	L1 (約)	L (約)
RT-4106	PT1/8	6	12	PF1/8	20	37
RT-4206	PT1/4	6	17	PF1/4	25	47
RT-4202	PT1/4	6.35	17	PF1/4	25	47
RT-4208	PT1/4	8	17	PF1/4	26	48
RT-4303	PT3/8	9.53	21	PF3/8	30	55
RT-4310	PT3/8	10	21	PF3/8	30	55
RT-4403	PT1/2	9.53	21	PF3/8	35	64
RT-4410	PT1/2	10	21	PF3/8	35	64

二方リングチーズ

C3604BD

C3771BD

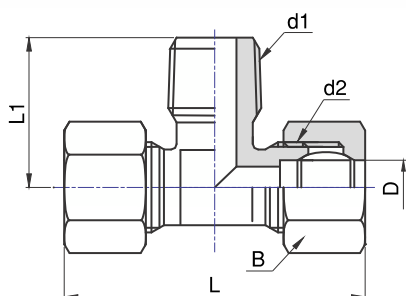

品番	取付ネジ	適用管外径 φD	寸法 (mm)			
	d1		B	d2	L1	L (約)
RT-2104	PT1/8	4	12	PF1/8	17	38
RT-2105	PT1/8	5	12	PF1/8	17	38
RT-2106	PT1/8	6	12	PF1/8	17	40
RT-2102	PT1/8	6.35	17	PF1/4	19	50
RT-2108	PT1/8	8	17	PF1/4	19	52
RT-2206	PT1/4	6	17	PF1/4	22	50
RT-2202	PT1/4	6.35	17	PF1/4	22	50
RT-2208	PT1/4	8	17	PF1/4	22	52
RT-2203	PT1/4	9.53	21	PF3/8	24	60
RT-2210	PT1/4	10	21	PF3/8	24	60
RT-2306	PT3/8	6	17	PF1/4	25	54
RT-2302	PT3/8	6.35	17	PF1/4	25	54
RT-2308	PT3/8	8	17	PF1/4	25	56
RT-2303	PT3/8	9.53	21	PF3/8	25	60
RT-2310	PT3/8	10	21	PF3/8	25	60
RT-2312	PT3/8	12	24	PF1/2	28	72
RT-2304	PT3/8	12.7	24	PF1/2	28	74
RT-2403	PT1/2	9.53	21	PF3/8	29	70
RT-2410	PT1/2	10	21	PF3/8	29	70
RT-2412	PT1/2	12	24	PF1/2	29	72
RT-2404	PT1/2	12.7	24	PF1/2	29	74
RT-2415	PT1/2	15	27	PF5/8	32	82
RT-2405	PT1/2	15.88	27	PF5/8	32	82
RT-2606	PT3/4	19.05	30	PF3/4	34	88

リングナット

C3604BD

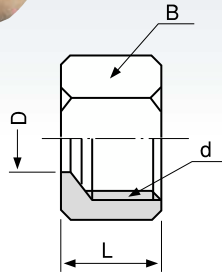

品番	適用管外径	寸法 (mm)		
	ϕD	d	B	L
RN-1004	4	PF1/8	12	10
RN-1005	5	PF1/8	12	10
RN-1016	6	PF1/8	12	11
RN-1026	6	PF1/4	17	13
※RN-1022	6.35	PF1/4	17	13
RN-1008	8	PF1/4	17	13
※RN-1033	9.53	PF3/8	21	15
RN-1010	10	PF3/8	21	15
RN-1012	12	PF1/2	24	18
※RN-1044	12.7	PF1/2	24	18
RN-1015	15	PF5/8	27	20
※RN-1055	15.88	PF5/8	27	20
RN-1066	19.05	PF3/4	30	23

※は六角カドにVミゾ入

リング玉

C3604BD

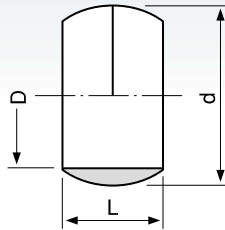

品番	適用管外径	寸法 (mm)	
	ϕD	d	L
RB-1004	4	6	5
RB-1005	5	7	5.5
RB-1016	6	8	6
RB-1026	6	9	6.5
RB-1022	6.35	9	6.5
RB-1008	8	10	7.5
RB-1033	9.53	13	9
RB-1010	10	13	9
RB-1012	12	14.8	10
RB-1044	12.7	15.5	10
RB-1015	15	18	12
RB-1055	15.88	19	12
RB-1066	19.05	22.5	13

フレアジョイント

C3604BD

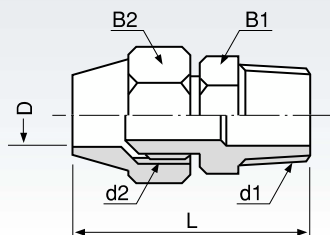

品番	取付ネジ	適用管外径	寸法 (mm)			
	d1	ϕD	B1	B2	d2	L(約)
FS-1106	PT1/8	6	12	16	UNF7/16×20	34
FS-1102	PT1/8	6.35	12	16	UNF7/16×20	34
FS-1108	PT1/8	8	14	17	UNF1/2×20	34
FS-1103	PT1/8	9.53	17	21	UNF5/8×18	36
FS-1110	PT1/8	10	17	21	UNF5/8×18	36
FS-1206	PT1/4	6	14	16	UNF7/16×20	37
FS-1202	PT1/4	6.35	14	16	UNF7/16×20	37
FS-1208	PT1/4	8	14	17	UNF1/2×20	37
FS-1203	PT1/4	9.53	17	21	UNF5/8×18	38
FS-1210	PT1/4	10	17	21	UNF5/8×18	38
FS-1212	PT1/4	12	22	24	UNF3/4×16	43
FS-1204	PT1/4	12.7	22	24	UNF3/4×16	43
FS-1306	PT3/8	6	17	16	UNF7/16×20	39
FS-1302	PT3/8	6.35	17	16	UNF7/16×20	39
FS-1308	PT3/8	8	17	17	UNF1/2×20	39
FS-1303	PT3/8	9.53	17	21	UNF5/8×18	40
FS-1310	PT3/8	10	17	21	UNF5/8×18	40
FS-1312	PT3/8	12	22	24	UNF3/4×16	45
FS-1304	PT3/8	12.7	22	24	UNF3/4×16	45
FS-1315	PT3/8	15	24	27	UNF7/8×14	49
FS-1305	PT3/8	15.88	24	27	UNF7/8×14	49
FS-1406	PT1/2	6	22	16	UNF7/16×20	42
FS-1402	PT1/2	6.35	22	16	UNF7/16×20	42
FS-1408	PT1/2	8	22	17	UNF1/2×20	42
FS-1403	PT1/2	9.53	22	21	UNF5/8×18	43
FS-1410	PT1/2	10	22	21	UNF5/8×18	43
FS-1412	PT1/2	12	22	24	UNF3/4×16	47
FS-1404	PT1/2	12.7	22	24	UNF3/4×16	47
FS-1415	PT1/2	15	24	27	UNF7/8×14	51
FS-1405	PT1/2	15.88	24	27	UNF7/8×14	51
FS-1615	PT3/4	15	28	27	UNF7/8×14	54
FS-1605	PT3/4	15.88	28	27	UNF7/8×14	54
FS-1606	PT3/4	19.05	28	32	UNS11/16×14	59

両口フレアジョイント

C3604BD

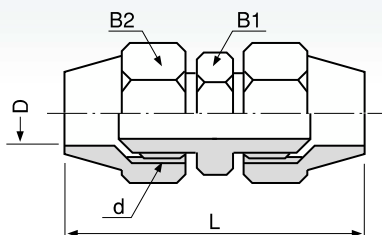

品番	適用管外径	寸法 (mm)			
	ϕD	B1	B2	d	L(約)
FS-2006	6	12	16	UNF7/16×20	46
FS-2022	6.35	12	16	UNF7/16×20	46
FS-2008	8	14	17	UNF1/2×20	46
FS-2033	9.53	17	21	UNF5/8×18	51
FS-2010	10	17	21	UNF5/8×18	51
FS-2012	12	22	24	UNF3/4×16	59
FS-2044	12.7	22	24	UNF3/4×16	59
FS-2015	15	24	27	UNF7/8×14	67
FS-2055	15.88	24	27	UNF7/8×14	67
FS-2066	19.05	28	32	UNS11/16×14	79